

International Gas Union Research Conference 2011

ALTERNATIVES TO ELECTRICITY FOR TRANSMISSION AND LOW-COST FIRING STORAGE OF LARGE-SCALE STRANDED RENEWABLE ENERGY AS PIPELINED HYDROGEN AND AMMONIA CARBON-FREE FUELS

William C. Leighty

The Leighty Foundation, Juneau, AK, USA

John H. Holbrook

Ampower LLC, Richland, WA, USA

ABSTRACT

Humanity must soon “run the world on renewables” – plus some degree of nuclear -- but cannot, and should not try to, accomplish this entirely with electricity transmission. We need to supply all energy, not just electricity, from diverse renewable energy (RE) resources, both distributed and centralized, where the world’s richest RE resources – of large geographic extent and high intensity – are stranded: far from end-users with inadequate or nonexistent gathering and transmission systems to deliver the energy. Electricity energy storage cannot affordably firm large, intermittent renewables at annual scale, while carbon-free gaseous hydrogen (GH₂) and liquid anhydrous ammonia (NH₃) fuels can, at < US\$ 1.00 / kWh capital cost: GH₂ in large solution-mined salt caverns, NH₃ in surface tanks, both pressurized and refrigerated.

Energy content of these fuels: 1 kg GH₂ = 39.4 kWh (HHV) or 33.3 kWh (LHV)

1 kg NH₃ = 6.3 kWh (HHV) or 5.2 kWh (LHV)

Higher heating value (HHV) and lower heating value (LHV) of fuels differ by the heat of vaporization of water.

We need to conceive, analyze, strategize, and commit to building complete RE systems, from photons and moving air and water molecules to firm and dispatchable energy services delivered to distant end-users. Natural gas energy systems may be a better model than a “smarter” electricity grid.

“Smart Grid” is emerging as primarily a DSM (demand side management) strategy to encourage energy conservation. Making the electricity grid “smarter” does not:

1. Increase physical transmission capacity;
2. Provide affordable annual-scale firming storage for RE;
3. Solve grid integration problem for large, time-varying RE;
4. Alleviate “not in my back yard” (NIMBY) objections to new transmission siting;
5. Reduce the high O&M costs of overhead electric lines.

The “smarter” grid may be more vulnerable to cyberattack than today’s grid. Adding storage, control, and power quality adjunct devices to the electricity grid, to accommodate very high RE content, may be technically and economically inferior to the GH₂ and NH₃ RE systems discussed here. Thus, we need to look beyond “smart grid”, expanding our concept of “transmission”, to synergistically and simultaneously solve the transmission, firming storage, and RE integration “balancing” problems now severely constraining our progress toward “running the world on renewables”.

Today’s energy industry is very water-intensive, consuming ~17,000 x 10⁹ liters of fresh water annually in USA. If total USA annual energy – from all sources, for all uses – were generated as RE-source electricity and converted to GH₂ and / or NH₃ fuels for transmission, total freshwater feedstock consumption, about one-fourth liter per kWh, would be ~900 x 10⁹ liters per year. This is far less than ~17,000 x 10⁹ liters the USA energy sector “consumed” in 2005. For example, a 1,000 MW windplant, operating at 40% capacity factor (CF), producing ~3,500 TWh (TWh = 10⁹ kWh) per year, would consume ~800 x 10⁶ liters of freshwater feedstock per year.

Transportation electrification does not necessarily require battery electric vehicles (BEV’s). GH₂ and / or NH₃ fuels would supply electric energy to the drive system via fuel cells, and may provide longer range at lower cost, greater energy security, and with better access to large, stranded, RE resources as annually-firm energy than an expanded and “smarter” electricity grid could provide.

The energy industry now needs to conceive, design, bid, build, and operate pilot plants by which to discover and demonstrate the technical and economic advantages – if any – of RE-source GH₂ and / or NH₃ fuel transmission, storage, and delivery systems, as humanity urgently proceeds to “run the world on renewables”.

TABLE OF CONTENTS

Abstract

- 1 Introduction
- 2 Transportation electrification
- 3 Renewable energy challenges at large scale
- 4 Transmission and storage systems comparison
 - 4.1 Electricity transmission and storage
 - 4.2 GH₂ transmission and storage
 - 4.3 NH₃ transmission and storage
 - 4.4 Energy required to “firm” Great Plains wind
 - 4.5 Storage cost comparison
- 5 Water: Feedstock required; disposition; oxygen byproduct
- 6 Pilot plants needed
- 7 Further work needed
- 8 Conclusion

Acknowledgement

Figures

1. Capital cost and rated transmission capacity: pipeline and electricity transmission
2. Capacity of gaseous hydrogen (GH₂) transmission pipelines
3. Polymer-metal pipe technology avoids hydrogen embrittlement (HE, HCC)
4. System topology options for wind-to-hydrogen gathering and transmission
5. Capital costs for GH₂ and anhydrous ammonia (NH₃) storage
6. Multiple large, solution-mined GH₂ storage salt caverns in “domal” salt
7. “Atmospheric” refrigerated liquid NH₃ tank stores 190,000 MWh
8. Both GH₂ and NH₃ provide very large capacity, low cost modular storage
9. NH₃ fuel network
10. NH₃ energy system for production from renewable energy (RE)
11. Complete RE systems analysis to guide humanity’s investments
12. Solid state ammonia synthesis (SSAS) alternative to electrolysis + Haber-Bosch
13. USA liquid NH₃ pipeline and storage terminal network

References

might capture some of this market because of its higher volumetric energy density than GH_2 , low-cost, low-pressure on-board vehicle storage tanks, and low-cost, low-technology pipeline transmission and refrigerated surface tank bulk energy storage. Figs 7, 9, 13.

3. RENEWABLE ENERGY CHALLENGES AT LARGE SCALE

The energy output of most renewables varies greatly, at time scales of seconds to seasons: the energy capture assets thus operate at inherently low capacity factor (CF); energy delivery to end-users is not “firm”. New electric transmission systems, or fractions thereof, dedicated to renewables, will suffer the same low CF, and represent substantial stranded capital assets, which increases the cost of delivered renewable-source energy.

We cannot achieve California AB32 and other ambitious greenhouse gas (GHG) emissions goals without fuel cell vehicles (FCV's) fueled with large quantities of zero-carbon-source GH_2 or NH_3 fuels. GH_2 pipelines may have a major role in humanity's energy future. Large-scale gathering, transmission, and distribution of RE-source GH_2 fuel in pipelines would be a major new industrial process, for which a pilot plant is required, on the critical path to discovering and demonstrating feasibility. No GH_2 pipelines for renewables-hydrogen service exist; the extensive extant industrial GH_2 pipeline system is not capable of renewables-hydrogen service, over hundreds of km with large and frequent pressure fluctuation. We report the results of several studies of the technical and economic feasibility of large-scale RE – hydrogen systems.^{6, 7, 8, 9, 10, 11, 12}

NH_3 is also an attractive transmission and storage medium, and strategy. Pressurized NH_3 storage and delivery infrastructure is very similar in design and performance to that for propane (LPG). The ICE, CT, and direct ammonia fuel cell operate very efficiently on NH_3 fuel. Energy, as liquid ammonia fuel, is stored inexpensively in 10 - 30,000 ton refrigerated surface tanks. Extensive pipeline and tank infrastructure is in place in USA. Figs 7, 13. Since ammonia can be shipped and stored in mild steel pipelines and tanks, any natural gas or petroleum pipeline could be easily converted to carry NH_3 .

Underground transmission pipelines, as would be required for GH_2 and NH_3 , are typically easier to site and permit than electric lines, and each may have multi-GW capacity. The USA Federal Energy Regulatory Commission (FERC) has jurisdiction over interstate pipelines, but not for electricity lines.

RE generation and conversion equipment may be relieved of the costly requirements to deliver “grid quality” AC (V, f, PF, and harmonics) as well as “low voltage ride through” (LVRT), because RE electricity is entirely delivered to electrolyzers and NH_3 synthesis systems. This may significantly reduce the capital and O&M costs of RE delivered to end-users.

The wind energy of the twelve Great Plains states, if fully harvested on about 50% of these states' aggregate land area, transmitted to distant markets, and “firmed” at annual scale with energy storage, could supply the entire annual energy demand of the USA: about 30,000 terawatt-hours (TWh = 10^9 kWh), equal to about 100 quads (quadrillion btu).¹³ However, existing Great Plains electric transmission export capacity is insignificant relative to this resource. Any large, new electric transmission systems, or fractions thereof dedicated to wind energy, will:

- Be very costly to build;
- Be difficult to site because FERC has no authority for permitting interstate electric lines;
- Be difficult to site and permit, because of public objection, as in NIMBY;
- Suffer the same low capacity factor (CF) as the windplants (typically 40%) and other RE plants they serve, unless RE generation is curtailed;
- Provide no affordable “firming” (weekly-to-annual scale) energy storage, thus taxing the “system balancing” ability of the electricity grid;
- Be vulnerable to damage by acts of God and man.

Two transmission and annual-scale, firming storage schemes seem technically and economically attractive for wind and other time-varying-output renewable electric energy sources at GW (nameplate) scale:

1. Conversion of electric energy to GH₂, by electrolysis of water, at high pressure (30 – 150 bar); GH₂ transmission and delivery by hydrogen-capable underground pipeline, with annual-scale firming storage of high-pressure GH₂ in deep, solution-mined salt caverns; Figs 3, 6.
2. Conversion of electric energy to NH₃, for transmission as liquid by underground pipeline, delivery via pipeline, rail, and truck, with annual-scale firming storage as liquid NH₃ in large (10,000 – 60,000 ton) refrigerated, above-ground tanks. Figs 9, 11, 13.

Without any expansion of electricity transmission capacity, or technology breakthroughs, RE may be totally converted to GH₂ or NH₃, transmitted over long distances using new or repurposed underground pipelines, firmed at annual scale in large GH₂ storage caverns and above-ground NH₃ tanks, and marketed as fuel for vehicles and for combined-heat-and-power (CHP) distributed generation in:

- Internal combustion engine (ICE) and combustion turbine (CT) gensets adapted for NH₃ fuel;
- PEM hydrogen fuel cells, for GH₂ and hydrogen “cracked” from NH₃;
- Direct-ammonia fuel cells.

The ICE operates efficiently on either GH₂ or NH₃ fuel, and is a mature technology for both. CT’s need further engineering to operate well on GH₂ or NH₃ fuels.

Total installed capital cost of large natural gas (NG) transmission pipelines, without compression, in year 2010 is ~\$US 25 per inch diameter per meter length for terrestrial, ~\$35 / inch / m for subsea. Compression adds ~15% to pipeline system capital cost. ^{14, 15, 16}

Pipeline costs vary considerably, among projects, and with material prices and contractor availability. We assume that NH₃ pipelines, and GH₂ pipelines fit for renewables-hydrogen service, can be built for the same cost as NG pipelines of the same diameter and rated pressure, assuming no incremental capital costs for GH₂ - capable line pipe, valves, and meters. Fig 3.

GW-km is a measure of the total transmission service provided by the system, useful for comparing transmission means and strategies. Large electric transmission lines cost about \$1 million per GW-km as proposed Frontier Line components. ¹⁷

Fig 2 shows the capacity of a 36” GH₂ pipeline 1,600 km long is ~6 GW; thus total system capacity is ~9,600 GW-km. From the estimate above, pipeline capital cost is ~ \$US 5.4 billion, assuming no GH₂ compression. Then, cost per GW-km is ~\$560,000

A 10” mild steel pipeline, 1,000 km long, for liquid NH₃ at ~20 bar, has a continuous capacity of ~1 GW ¹⁸, with adequate pumping at midline stations, which would be adequate for a 2.5 GW nameplate windplant with internal NH₃ output smoothing or firming storage. Pipeline total installed capital cost is ~\$320,000 per km, including pumping stations. A 1,000 km pipeline would cost ~\$US 320 million; total system capacity is 1,000 GW-km; cost per GW-km is ~\$320,000.

Fig 1. Thus, the relative capital cost of transmission systems may be compared, per GW-km:

Electricity, 500 kV, AC or DC	\$ 400 – 1,000K
GH ₂ pipeline, no compression	\$ 560K
Liquid NH ₃ pipeline, with pumping	\$ 320K

New underground pipelines are generally less controversial, thus faster and easier to site and permit, than new overhead electric transmission lines. FERC has jurisdiction over interstate pipelines, not over electric lines. Pipelines are generally better protected from acts of God and man.

4. TRANSMISSION AND STORAGE SYSTEMS COMPARISON

Fig 1. We estimate costs of transmission and annual-scale firming storage of diverse, GW-scale, stranded renewables at GW scale. No pilot plant exists for confirming the system capital costs and conversion efficiencies we estimate in this study, although both GH₂ and NH₃ have been proposed for wind energy transmission and storage. ³⁻⁹ Hydrogen is promising as a clean-burning energy carrier, and modern electrolyzers can produce large volumes of high-pressure hydrogen, ready for direct

pipeline transmission and/or for ammonia synthesis, from RE sources. Renewable-source electricity can alternatively be stored and transported as NH₃, which can be readily synthesized, following electrolysis, using atmospheric nitrogen, and be used at the delivery end-point as a fertilizer or a fuel. Both GH₂ and NH₃ transmission and firming storage will accelerate our conversion from fossil to diverse renewable resources, via major new markets including, and beyond, the electricity sector.

If we find compelling the low capital cost (<\$1 / kWh) of gaseous hydrogen (GH₂) and liquid anhydrous ammonia (NH₃) storage, we should consider solving all three problems of high-percentage-penetration of renewable energy (RE) on the electricity grid -- gathering and transmission, firming storage, grid integration -- via complete GH₂ and / or NH₃ systems at continental and multi-GW scale, which might be key to "running the world on renewables", as we eventually must.

All storage systems suffer the capital costs and energy conversion losses of transition to and from the energy supply and the storage medium. GH₂ and NH₃ conversion costs may be higher than for some "electricity" storage systems, but may be justified by the ability of the complete renewable energy (RE) system to bring RE all the way from photons, moving air and water molecules, and other sources to the firm, dispatchable, energy services required by humans.

4.1 Electricity transmission and storage

Making the electricity grid "smart" will add slight virtual transmission capacity but no physical capacity. The marginal cost of grid integration for wind, and other renewables, will increase with the fraction of total energy supplied by renewables (except geothermal), in spite of valiant technical and policy integration efforts.¹⁹

Several hundred GW of new electricity transmission for RE, as proposed in Frontier Line, Green Power Express, Trans West Express, Clean Line, and others:

- a. Accommodate, in aggregate capacity, only a small fraction of the RE needed to meet climate change mitigation goals;
- b. May be blocked, for too long, by local jurisdictions and popular opposition;
- c. Cannot presently benefit from FERC, which lacks interstate jurisdiction for electricity line right-of-way and permitting.

Our electricity transmission cost benchmarks are Clean Line proposals and the Frontier Line Feasibility Study, which considered many multi-GW electricity transmission expansions, all at 500 kV, both AC and DC, from Wyoming south and west, with these typical results²⁰:

- AC line construction cost \$ 29.90 / MWh
- DC line construction cost \$ 19.10 / MWh
- California system integration \$ 3.00 / MWh
- Line losses \$ 1.80 / MWh

Analysis of individual Frontier Line transmission links gives these mean capital costs for mixed AC and DC lines:

- Per GW \$ 619 million
- Per mile \$ 4.9 million
- Per GW-mile \$ 1.4 million
- Per GW-km \$ 0.9 million

Analysis of complete Frontier Line transmission system alternatives gives these mean capital costs:

- Per GW \$ 1,375 million
- Per mile \$ 3.2 million
- Per GW-mile \$ 0.8 million
- Per GW-km \$ 0.5 million

GW-mile and GW-km are measures of the total transmission service provided by the system. Whether these Frontier Line estimates include ROW lease or purchase is unknown. Large electric transmission lines cost \$500K – \$1,000K per GW-km. We found the Clean Line transmission proposals to be comparable.

4.2 GH₂ transmission and storage

GH₂ transmission requires line pipe material and system components able to resist and control, or be immune to, hydrogen embrittlement (HE). In contrast, NH₃ pipelines are moderate-strength, low-alloy, carbon steel. NH₃ does not attack steel.

Fig 3 shows one solution to the HE danger, whereby the structural strength of steel is replaced by fiber-reinforced plastic (FRP) and the GH₂ permeation barrier is reduced to a thin Cu or Al foil. This FRP linepipe can be fabricated on-site in a continuous process at an “all-in” capital cost of the commissioned pipeline of ~\$125 / inch diameter / m length.²¹

Fig 4. Without any expansion of the electricity transmission grid, all RE is converted at the windplant or other RE plant to GH₂ fuel. High-pressure-output electrolyzers feed the pipeline directly at ~100 bar, from wind or other RE electricity sources. Other RE-source GH₂ may be delivered to the pipeline via compressors and a simple node at any point. Wind and other RE generators are interconnected via pipelines rather than via field-voltage electricity collection cables. The oxygen byproduct of electrolysis may be sold to adjacent coal and dry biomass gasification plants. A small amount of distribution-level electricity is required for the RE generation control systems.

Fig 6. GH₂ is stored at 100-150 bar in solution-mined salt caverns, typically 800,000 cubic meters physical volume, capable of storing ~ 2,500 net tons of GH₂ in addition to ~2,000 tons of “cushion” GH₂. The cavern top is typically ~800 m below ground level. The surface facility provides compression (if needed), GH₂ gas drying upon withdrawal, manifolding of multiple caverns in a storage array, and metering. Typically, capital cost of a completed facility is half cavern excavation, half surface facility. In Texas onshore domal salt, in a multi-cavern facility achieving maximum economy of scale, each cavern will cost ~\$15-20 million (including cushion gas) and will store ~2,500 net tons GH₂ (~90,000 MWh as the chemical energy of hydrogen). Leakage and O&M cost, except for compression energy (if required), are very low, in ConocoPhillips twenty years’ experience with their Clemens Terminal hydrogen cavern near Moss Bluff, TX.²²

About 15,000 such salt caverns could firm, at annual scale, the entire Great Plains, USA, wind resource, as GH₂ fuel, to supply total USA energy (from all sources, for all uses): ~30,000 TWh (~100 quads) per year. Synergy with solar and other renewables would reduce required cavern storage, perhaps dramatically. However, customers must now purchase energy only as GH₂ fuel.

Germany considers GH₂ cavern storage more attractive than compressed air energy storage (CAES) for integrating wind on their electricity grid.²³

4.3 NH₃ transmission and storage

Iowa State University has hosted six annual Ammonia Fuel Conferences, which include NH₃ as an RE transmission and storage medium, as well as a transportation and distributed generation fuel.²⁴

NH₃ contains no carbon; has physical properties similar to propane; liquefies at ambient temperatures at about 10 bar or at -33 degrees C at 1 atmosphere. Liquid ammonia has over 50% more volumetric energy than liquid hydrogen; more than twice the volumetric energy of hydrogen gas at 700 bar. It is the second-largest-volume industrial chemical in global trade: ~130 million tons (MMt) per year, mostly for N-fertilizer. USA consumes ~12 - 15 MMt / year, with a good safety record. NH₃ is classified as an “inhalation hazard”.

NH₃ is nearly 18% hydrogen by weight and has slightly over half the energy density of gasoline by volume. All of ammonia’s energy is derived from its hydrogen content; it can be easily reformed to hydrogen and nitrogen, with N₂ returned to its source, Earth’s atmosphere. NH₃ has the highest hydrogen content by volume of any liquid fuel, including gasoline, liquefied natural gas (LNG), liquefied petroleum gas (LPG, propane), ethanol, and even liquid hydrogen. Liquid anhydrous ammonia, NH₃, has more atoms of hydrogen per liter than liquid hydrogen. This ability of NH₃ to store hydrogen very compactly at ambient temperature and moderate pressure is a key advantage for NH₃ over GH₂.

Like hydrogen, ammonia can burn directly in spark-ignited internal combustion engines and may also be fed directly to medium temperature solid oxide, proton-conducting ceramic, and molten-salt direct-ammonia fuel cells. Ammonia combusts according to:

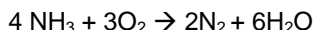

with only nitrogen and water vapor as combustion products. Like hydrogen, ammonia is lighter than air and is not a greenhouse gas.

Figs 9 and 11 show NH_3 value as an alternative to electricity for GW-scale RE transmission and storage. However, the available, conventional electrolysis-plus-Haber-Bosch (H-B) synthesis process has too much capital cost in components operating at low CF, with the estimated cost of wind-source NH_3 at the plant gate > \$1,000 / Mt, which is not competitive with domestic or imported fossil-source NH_3 . Consequently, solid state ammonia synthesis (SSAS), shown in Figs 10, 12, was developed to reduce the cost of RE-source NH_3 . However, SSAS has not yet been demonstrated at commercial scale.

Figs 9 and 13 show that a safe, reliable, proven ammonia delivery and storage infrastructure already exists in the US. Approximately 3,000 miles of carbon-steel ammonia pipeline is in service in America's agricultural heartland, mainly in the Corn Belt. NH_3 pipelines are moderate-strength, low-alloy, carbon steel; NH_3 does not attack steel. Almost a hundred large terminals for refrigerated ammonia storage are distributed along the pipeline. Barges, trains, and trucks round out the delivery system, which supplies the ammonia from the terminal to the farmer when he needs it for the growing season. The state of Iowa, alone, has over 800 retail outlets where farmers buy "anhydrous" or "nitrogen", the vernacular for ammonia fertilizer, NH_3 .

About 20,000 MW of nameplate Great Plains wind generation would be needed to produce 6 million tons of NH_3 per year, about one-third of the present USA demand for ammonia-based fertilizer. This estimate is based on an overall 50% efficiency of converting wind power into energy stored as NH_3 . Several times as much wind, or other RE generation, would be needed to produce all of the USA NH_3 demand, especially if NH_3 also becomes widely adopted as a fuel.

Fig 7. A large, liquid ammonia "atmospheric" storage tank typical in the Corn Belt, USA, stores refrigerated NH_3 at 1 atm, -33C. Typical capacity is 30,000 MT, equal to 190 GWh as hydrogen reformed from NH_3 . This size mild steel, double-wall tank capital cost is ~\$15M, or ~\$77 / MWh.

4.4 Energy storage required to "firm" Great Plains wind

- We require "firm", "dispatchable" energy, which by definition means that, every hour of every year:
- A supplier and buyer can contract for an agreed amount of energy;
 - Real-time energy demand, for all customers, is managed met.

Consider the quantity of GH_2 storage required to "firm" the output of a large 2,000 MW (nameplate) Great Plains windplant which produces ~7 TWh in an average year. Using the numbers from "Seasonal Variability of Wind Electric Potential in the United States" ²⁵, Table 3, for "North Central", normalized, yields these "seasonality factors" as ratio to 1.0 nominal, constant seasonal production:

Winter 1.20 Spring 1.17 Summer 0.69 Autumn 0.93

We find that expected average seasonal energy production for the 2,000 MW windplant would be (7 TWh / 4 seasons) = (1.75 TWh) x seasonality factor, above:

Winter =	1.75 x 1.20 =	2.10 TWh
Spring =	1.75 x 1.17 =	2.05 TWh
Summer =	1.75 x 0.69 =	1.21 TWh
Autumn =	1.75 x 0.93 =	1.63 TWh

The biggest difference between seasons is between Winter and Summer: 2.10 – 1.21 = 0.89 TWh. If all windplant energy is converted to GH_2 for export, at the 75% efficiency typical of large-scale electrolyzers, this is apparently 0.71 TWh of GH_2 storage needed. However, the biggest difference between adjacent, sequential seasons is between Spring and Summer: 2.05 – 1.21 = 0.84 TWh. If all windplant energy is converted to GH_2 for export, at 75% electrolyzer efficiency, apparently [0.84 x

0.75 = 0.63] TWh = 630 GWh of GH₂ storage is needed. The latter case is more relevant. Stored as “electricity” at 100% round-trip ideal efficiency, without the 25% energy conversion loss typical in electrolysis, ~470 GWh storage would be needed; ~235 GWh storage per GW wind nameplate.

Thus, geologic storage needed to seasonally “firm” 2,000 MW (nameplate) of Great Plains wind, over the maximum average seasonal variation, is: 0.63 - 0.03 = 0.6 TWh, which is equivalent to ~18,000 metric tons (MT) of GH₂, requiring ~6 caverns shown in Fig 6.

USA has several salt deposit realms with formations deep and tight enough to store GH₂ in man-made caverns at 150 bar with negligible leakage. Fig 6 shows GH₂ storage caverns. Total capital cost for the 6 required GH₂ caverns would be about \$95M; for the 4 required NH₃ tanks would be about \$90M. The wind or other RE is now sold as GH₂ or NH₃ fuels for vehicles and DG of electricity in stationary CHP.

Annual-scale firming of the output of a 2,000 MW (nameplate) windplant in the northern Great Plains requires energy storage of approximately:

- 470,000 MWh as electric energy, for which no affordable mechanism exists, or
- 18,000 tons of GH₂, requiring about 6 large, solution-mined salt caverns, or
- 110,000 tons of NH₃, requiring about 4 typical, large, refrigerated, above-ground tanks.

GH₂ transmission pipelines are likely to operate at 100 – 150 bar maximum input pressure, with city-gate delivery at ~30 bar. An 800 km, 20” diameter GH₂ pipeline, packed to 130 bar and unpacked to 65 bar, stores 936 tons of GH₂ = 33,500 MWh. = 0.03 TWh, which we assume for this analysis.

No affordable electric energy storage technique or system capable of 470,000 MWh, for annual-scale firming of this quantity of Great Plains wind, is available or anticipated. Storing 470,000 MWh would require ~37,000 VRB-ESS battery systems, discussed in 4.5 below, at total capital cost > \$US 100 billion, if mass production halved VRB-ESS cost and if the optimum power: energy ratio for VRB-ESS components were determined.

Compressed air energy storage (CAES) may provide lower-cost “electricity” storage, but we will need to analyze as-built storage capacity and capital and O&M costs for the proposed Iowa Stored Energy Park. No CAES plants have been built for decades, so costs are uncertain. Continental CAES capacity may be too geologically limited to facilitate the very large scale RE supply of firm energy humanity needs.

The oxygen byproduct of water electrolysis may be sold to adjacent new dry biomass and / or coal gasification plants, likely to be prevalent in the Great Plains. However, oxygen cannot be pipelined far at competitive cost.

Consider the optimistic estimated cost of annual firming storage for 1 GW nameplate wind-source NH₃ production in a complete SSAS system with a 1,600 km NH₃ transmission pipeline:

Total Installed Capital Cost: 1,600 km pipeline with “Firming” NH₃ tank storage:
Windplant size 1,000 MW nameplate

Wind generators	\$ 1,000 [million]
ASU (air separation unit)	100
SSAS Reactors	500
Pipeline, 10”	500
(2) NH ₃ storage tanks @ \$15M ea	30
TOTAL	\$ 2,130

Tank storage: ~1 % of total capital cost

4.5 Storage cost comparison

Figs 5, 8. Delivering annually-firm energy from Great Plains wind will require ~300 - 500,000 MWh of storage per 1,000 MW of nameplate wind capacity. At this seasonal scale, power (charge and discharge rate) rating is much less important than energy rating. The vanadium-redox battery energy storage system (VRB-ESS) presently provides the lowest-cost bulk electricity storage. VRB Power Systems, Canada, will sell a VRB-ESS flow battery to Tapbury Management, County Donegal, Ireland, for \$US 6.3 million: 1.5 MW (charge and discharge rate), 12 MWh (total energy storage capacity) . Estimated capital costs of 300,000 MWh storage:

As "electricity" in Vanadium Redox Battery (VRB)	\$100B
As GH ₂ in salt caverns	\$100M
As NH ₃ in "atmospheric" surface tanks	\$ 90M

Relatively little energy is required to compress GH₂ to ~ 150 bar for optimal salt cavern economic utilization, and to dry the GH₂ upon withdrawal from the cavern.

Relatively little energy is required to refrigerate the large (10-30,000 Mt) "atmospheric" NH₃ storage tanks and to pump the pressurized liquid NH₃ upon withdrawal from the tank.

Arraying multiple caverns and tanks to increase total storage capacity while sharing balance-of-plant infrastructure would further reduce energy capacity capital and O&M costs.

5. WATER: FEEDSTOCK REQUIRED; DISPOSITION; OXYGEN BYPRODUCT

In the USA in 2005, energy production "consumed" ~17,000 x 10⁹ liters per year of fresh water, although most of this is "borrowed" from rivers and lakes for fossil and nuclear thermoelectric generation cooling and returned to the same water body.²⁶ Conversion of RE-source electricity to GH₂ and NH₃ fuels withdraws and disintegrates the H₂O molecules, which reappear, reintegrated, at the energy end-user when the fuel's hydrogen atoms are oxidized, releasing energy and the byproduct high-purity H₂O – which may be valuable. The byproduct O₂ may be valuable where produced at the RE source, if it can be sold to adjacent biomass or coal gasification plants or for other local uses; O₂ cannot be economically shipped far.

We are thus shipping water from RE source to market, by pipelining hydrogen, as H₂ or NH₃, while the oxygen is shipped at no cost via Earth's atmosphere. For RE resources in arid areas, the freshwater supply may need to be imported from the energy delivery market(s), perhaps via a pipeline collocated with the GH₂ or NH₃ fuel export pipeline, probably at a small increment to total RE plant capital cost.

About one-fourth liter (kg) of H₂O freshwater feedstock per kWh of GH₂ or NH₃ fuel energy is required. For example, a 1,000 MW windplant, operating at 40% capacity factor (CF), producing ~3,500 TWh (TWh = 10⁹ kWh) per year, would consume ~800 x 10⁶ liters of freshwater feedstock per year.

Therefore, if total USA energy, for all uses, ~30,000 TWh per year, were derived entirely from wind and solar PV generation, which consume no water in energy generation, and entirely converted to GH₂ and NH₃ fuels for transmission, storage, and distribution, total H₂O feedstock consumed would be ~900 x 10⁹ liters per year of fresh water – far less than the ~17,000 x 10⁹ liters the USA energy sector "consumed" in 2005.

Turner estimated in 2004 that conversion of the current USA light-duty fleet (~230 million vehicles) to fuel cell vehicles would require ~380 x 10⁹ liters (~100 x 10⁹ gallons) of water [electrolysis feedstock only] per year to supply the needed hydrogen.²⁷

6. PILOT PLANTS NEEDED

We should assemble consortia to begin immediately to design and build pilot plants for RE-source GH_2 and NH_3 transmission, firming storage, delivery, and end-use, by which to discover and demonstrate their technical and economic feasibility – or lack thereof. Tasks:

- Conceive: perform technical and economic feasibility studies; describe needed upstream R&D;
- Design: propose preliminary design specifications;
- Design: release a credible RFP or RFQ to determine costs to design, build, and operate;
- Build, own, operate: assemble a collaborative to fund the projects, to supply renewable-source GH_2 and NH_3 fuels to the pilot plants, and to use the delivered fuels.

This pilot plant concept has been proposed for GH_2 as the International Renewable Hydrogen Transmission Demonstration Facility (IRHTDF).²⁸ NH_3 fuel utilization demonstrations are easy, as the fuel is widely available as N-fertilizer: Fig 13. RE-source NH_3 synthesis plants will be more costly.

7. FURTHER WORK NEEDED

1. Develop new technologies and components for higher energy conversion and synthesis efficiency at lower capital and O&M costs. Continuous improvement via R&D and demonstrations for both GH_2 and NH_3 fuels.

2. Figs 10, 12. Solid state ammonia synthesis (SSAS), now a patented laboratory-scale device, needs R&D and demonstration at ~100 kW synthesis module scale, to learn whether it offers an economically-superior path to RE-source NH_3 production, vis-à-vis the Haber-Bosch synthesis path, and likely scaleup to MW scale.

3. Model continental-scale, multi-GW RE systems, to suggest optimum mix of electricity, GH_2 , NH_3 , and perhaps other transmission and firming storage strategies. This is consistent with the USDOE Strategic Plan 2011: “Catalyze the timely, material, and efficient transformation of the nation’s energy system...”²⁹

8. CONCLUSION

We are trying to stuff a square peg into a round hole, as we urgently transform the world’s largest industry – energy – to “run the world on renewables” plus some hard-to-predict degree of nuclear, via electricity: it is not well suited to gathering and delivering diverse, dispersed, diffuse, time-varying-output RE to distant markets as firm and dispatchable energy. Natural gas energy transmission and storage systems may be a better model than the electricity grid, for humanity’s urgent, superordinate goal to replace all fossil-source with RE-source energy.

Only expanding, and making “smarter”, the electricity gathering-transmission-storage-distribution grid will not allow replacing fossil-source energy with RE-source energy quickly enough to meet humanity’s goal of preventing rapid and catastrophic climate change, by quickly reducing GHG emissions. “But this vision is also too good to be true... an incremental technology trend well under way rather than a disruptive technology that will transform the power sector in the next decade...”^{30, 31}

We will need other transmission and storage media, systems, and strategies, in addition to electricity. GH_2 and NH_3 are attractive alternatives, for which pilot plants should soon be built, in order to discover and demonstrate their technical and economic feasibility and their acceptability to the public and to the business and finance communities. Both GH_2 and NH_3 provide affordable seasonal-to-annual-scale firming storage for diverse RE resources, at < US\$ 1.00 / kWh capital cost, as well as

the transmission paths for bringing GW-scale, stranded RE to distant markets. End-users purchase their energy as GH_2 and / or NH_3 fuels, for:

- CHP on-site generation;
- Centralized generation, with and without CHP;
- Transportation fuels;
- Space-conditioning;
- Diverse industrial uses.

RE-source GH_2 and NH_3 fuel systems should greatly reduce global and local freshwater consumption vis-à-vis today's thermoelectric electricity generation and oil and gas energy industries.

Transmission pipelines for both GH_2 and NH_3 fuels have multi-GW capacity over hundreds of km. These RE systems, as alternatives to electricity, deserve more serious technical and economic consideration than the authors are able to provide; we believe we have set the stage.

ACKNOWLEDGEMENT

The authors gratefully acknowledge the contributions of Dr. J. G. Blencoe, Hydrogen Discoveries, Inc., to this paper.

Figures

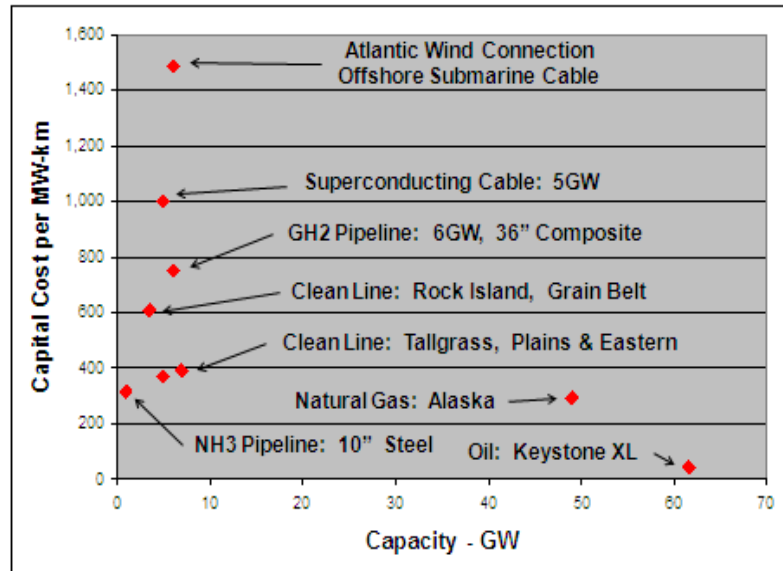

Figure 1. Capital cost and rated transmission capacity for hydrocarbon pipelines (blue), RE-source pipelines (red), and electricity. Pipelines are underground. See proposed Alaska North Slope (ANS) Gasline³²

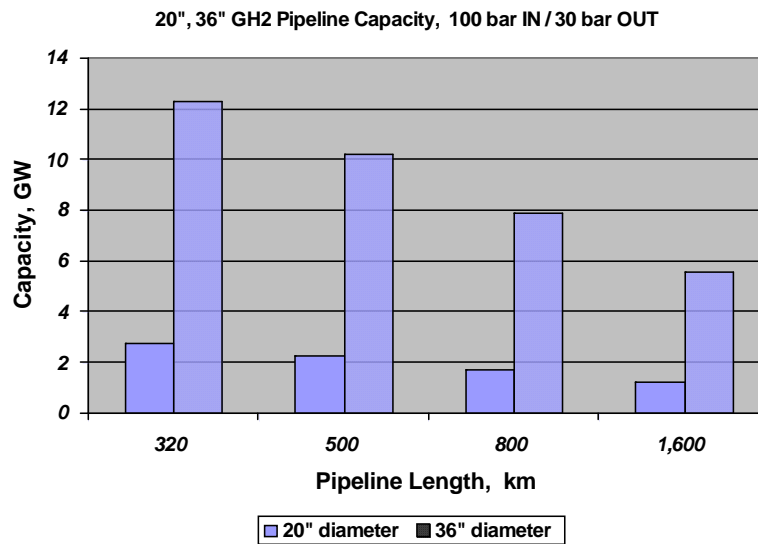

Figure 2. Capacity of gaseous hydrogen (GH₂) transmission pipelines, assuming: no input or midline compression; high-pressure-output electrolyzers deliver directly to pipeline at 100 bar; pipeline friction losses are accepted; delivery to city-gate market at 30 bar. Total transmission service capacity of an 800 km, 36" pipeline is ~6,400 GW-km.

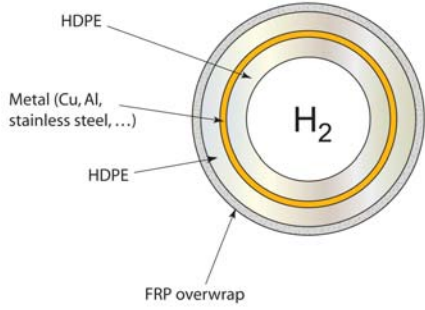

Figure 3. Hydrogen Discoveries, Inc. (HDI) Polymer/Metal Pipe Technology, which avoids hydrogen embrittlement (HE, HCC) by eliminating alloy steel as a structural material. Primary GH₂ diffusion barrier is a thin metal foil. This pipe can be fabricated up to 1m diameter, in the field, in unlimited lengths.

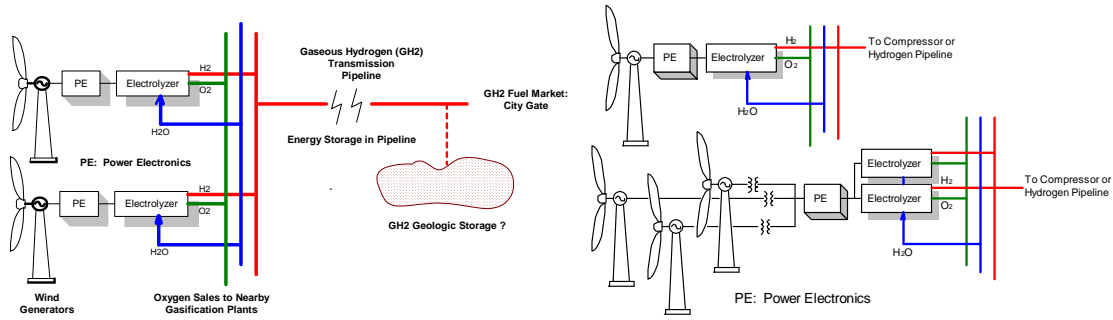

Figure 4. System topology options for wind-to-hydrogen energy conversion, gathering, and transmission. The hydrogen may be delivered to transmission pipelines or to nearby NH₃ synthesis plants. Both GH₂ and NH₃ may be stored, for affordably firming wind and diverse other RE resources.

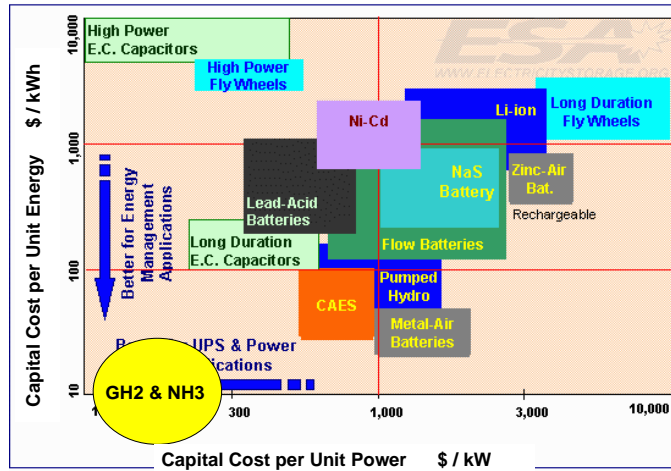

Figure 5. Capital cost for modular gaseous hydrogen (GH₂) storage in salt caverns and anhydrous ammonia (NH₃) storage in “atmospheric” surface tanks is low. Power cost is fluid handling and pumping.³³

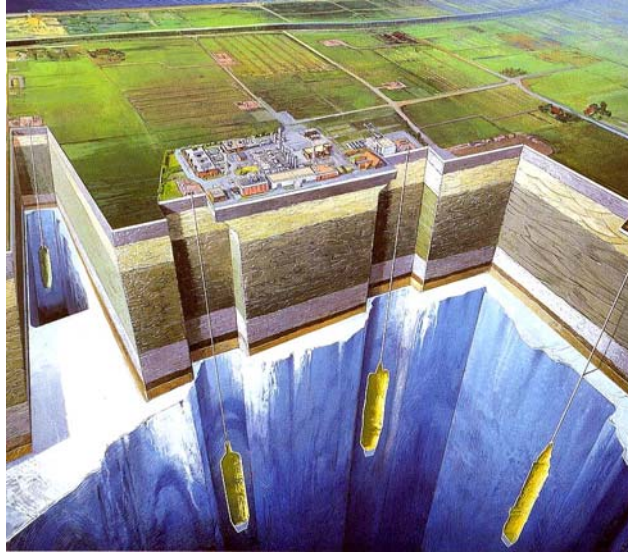

Figure 6. Multiple large, solution-mined salt caverns in “domal” salt, suitable for high-pressure storage of GH₂. A typical cavern will store 90,000 MWh as 2,500 net Mt of GH₂ at 70-150 bar in ~800,000 cubic meters physical volume. Total capital cost of cavern, GH₂ cushion gas, and shared surface facility is ~ \$15M; ~\$0.20 / kWh



Figure 7. “Atmospheric” refrigerated liquid anhydrous ammonia (NH₃) tank stores 190,000 MWh as 30,000 Mt of NH₃ fuel. Total capital cost ~\$15M; ~ \$0.10 / kWh

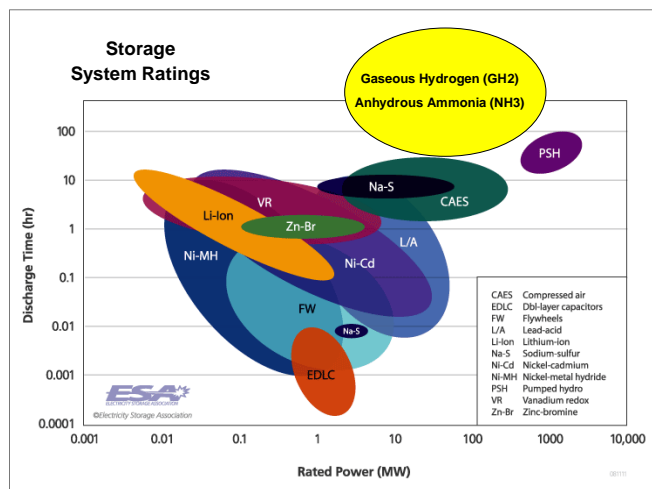

Figure 8. Both GH₂ and NH₃ provide very large capacity, low cost modular storage for annual-scale firming of diverse RE resources. ³⁴

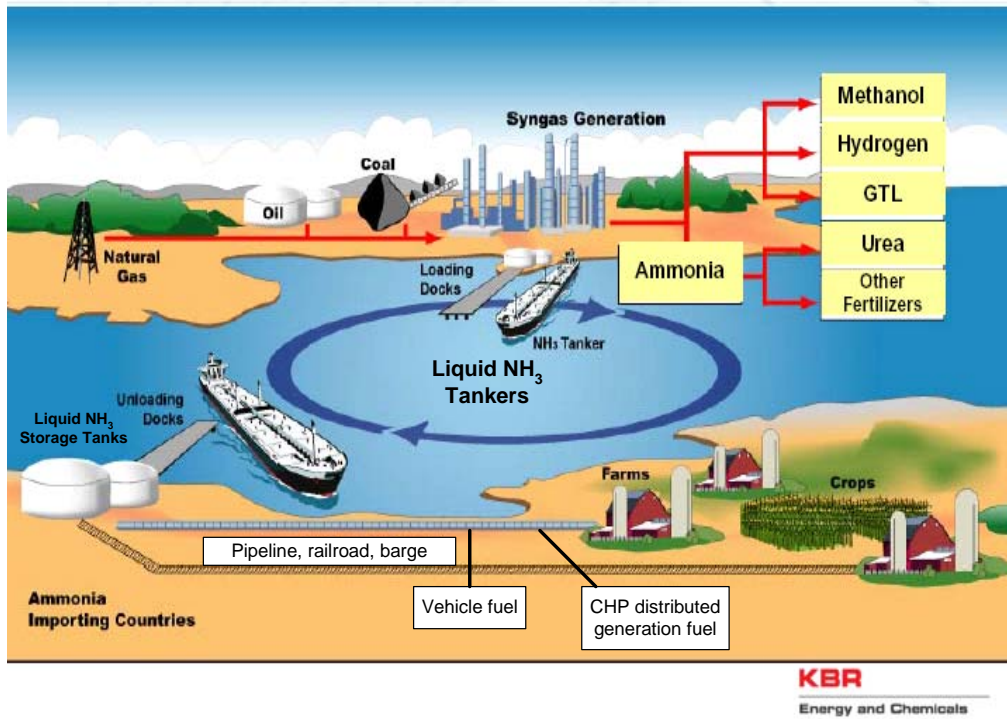

Figure 9. Anhydrous Ammonia NH_3 Fuel Network. This paper assumes NH_3 production entirely from RE resources, with primarily terrestrial pipeline transmission. Globally, NH_3 is the second-largest volume industrial chemical.

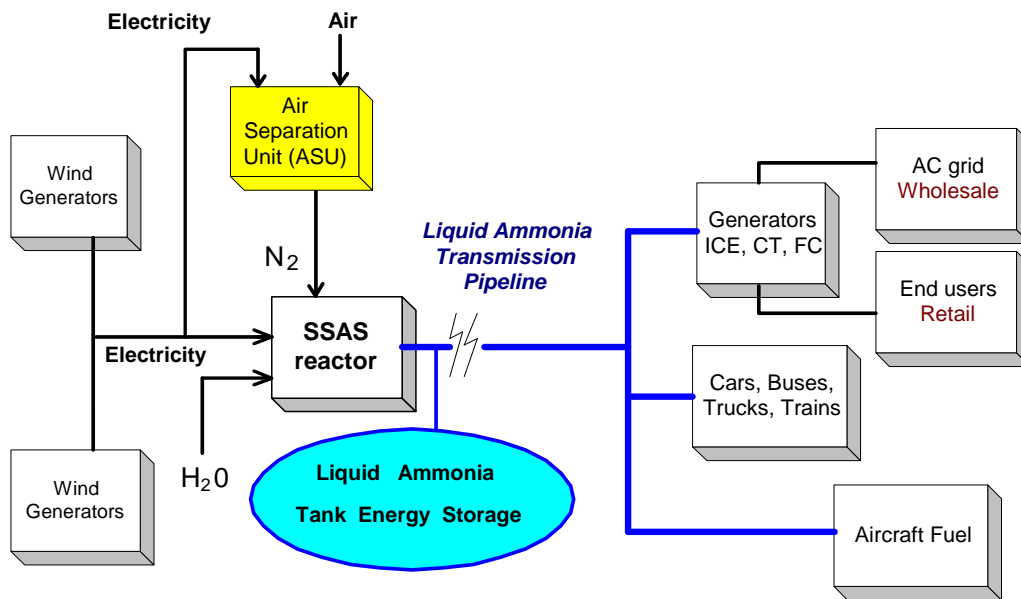

Figure 10. NH_3 energy system: production from RE, with large-scale, low-cost energy storage and transmission for fuel distribution at distant markets. SSAS is Solid State Ammonia Synthesis.

Energy as a Complete System: Generation, Usage, Storage, Transmission

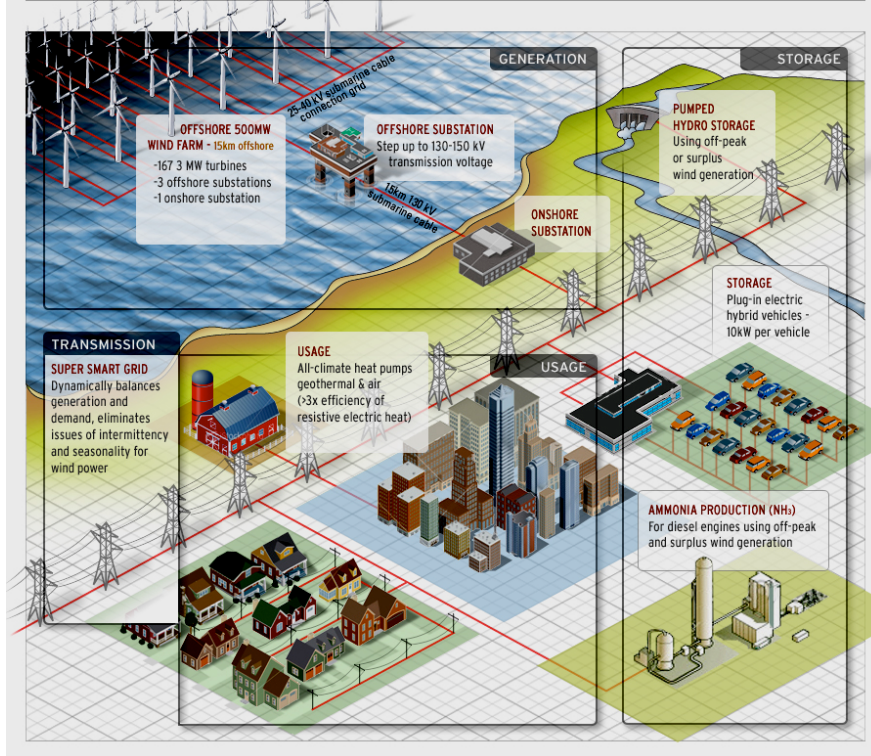
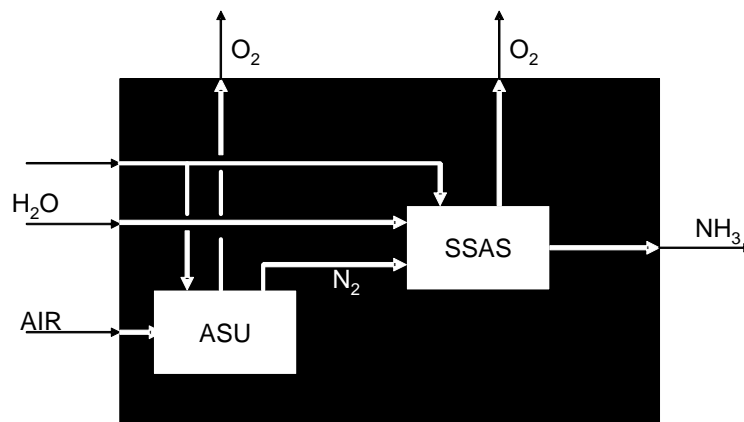
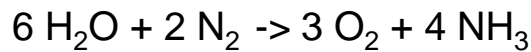

Figure 11. Complete RE systems analysis must guide humanity's investments in diverse, yet complementary, transmission, firming, and distribution strategies. Note Ammonia Production, for which inexpensive storage tanks are available.



Energy consumption 7,000 – 8,000 kWh per ton NH₃

Figure 12. Solid state ammonia synthesis (SSAS), an alternative to electrolysis plus Haber-Bosch synthesis, for NH₃ production from RE. Estimated energy conversion efficiency. As SSAS pilot plant has been proposed but not yet built. SSAS reactor construction uses proton conducting ceramic (PCC) tubes in a structure similar to a solid oxide fuel cell (SOFC).



Figure 13. Extant USA liquid NH_3 pipeline and storage terminal network, handling ~12-15 MMT per year, primarily for N-fertilizer, of which ~60% is imported.

REFERENCES

- ¹ Narayanamurti, V., Anadon, L., Sagar, A. (2009) Transforming Energy Innovation, Issues in Science and Technology, National Academies, Vol XXVI, No.1, Fall 2009, p. 57-64
- ² <http://www.oceanenergy.org/energysystem.asp>
- ³ Delucchi, M.A., Jacobson, M.Z., (2011) Providing all global energy with wind, water, and solar power, Part II: Reliability, system and transmission costs, and policies. Energy Policy (2011), doi:10.1016/j.enpol.2010.11.045
- ⁴ Phyllis Cuttino, Director, Clean Energy Program, Pew Environment Group, on panel 16 Feb 11 at Environmental Grantmakers Association meeting, Washington, DC
- ⁵ Committee on Alternatives and Strategies for Future Hydrogen Production and Use, National Research Council 2004 *The Hydrogen Economy: Opportunities, Costs, Barriers, and R&D Needs* (Washington, DC: National Academies Press)
- ⁶ Holbrook, J., Leighty, W. (2007) Transmission and firming of GW-Scale wind energy by ammonia pipelines and tanks, Proceedings of Windpower 07, AWEA, Los Angeles, June 07
- ⁷ Leighty, W., Hirata, M., O'Hashi, K., Benoit, J. (2004) Large stranded renewables: the international renewable hydrogen transmission demonstration facility (IRHTDF). Proceedings of the 19th World Energy Conference, Sydney, AUS, Sept 04.
- ⁸ Leighty, W., Holloway, J., Merer, R., Somerday, B., San Marchi, C., Keith, G., White, D. (2006) "Compressorless hydrogen transmission pipelines deliver large-scale stranded renewable energy at competitive cost". Proceedings of the 16th World Hydrogen Energy Conference, Lyon, FR, June 06.
- ⁹ Leighty, W., Hirata, M., O'Hashi, K., Benoit, J., Keith, G. (2003) Large renewables-hydrogen energy systems: gathering and transmission pipelines for windpower and other diffuse, dispersed sources. Proceedings of the 22nd World Gas Conference, IGU, Tokyo, Jun 03.
- ¹⁰ O'Hashi, K., Hirata, M., Leighty, W. (2006) From a natural-gas-based to a hydrogen-based society: Proposal for a Northeast Asian hydrogen highway. Proceedings of the 23rd World Gas Conference, IGU, Amsterdam, NL, June 06
- ¹¹ Holbrook, J., Leighty, B. (2008) Transmission and firming of GW-Scale wind energy via hydrogen and ammonia, *Wind Engineering*, VOLUME 32, NO. 1, 2008, vol. 3, pp. 549-557, Apr. 2008.
- ¹² Leighty, W. (2008) Running the world on renewables: Hydrogen transmission pipelines and firming geologic storage, Int. J. Energy Res. 2008; 32:408–426 Published online 17 January 2008 in Wiley InterScience (www.interscience.wiley.com) DOI: 10.1002/er.1373
- ¹³ Elliott, D., Wendell, L., Gower, G. (1991) An assessment of the available windy land area and wind energy potential in the contiguous United States. Pacific Northwest Laboratory, PNL-7789 / NTIS no. DE91018887, September, 1991.
- ¹⁴ http://www.isepa.com/about_isep.asp
- ¹⁵ Personal communication, 4 Dec 07, with Dr. Mo Mohitpour, Tempsys Pipeline Solutions, BC, Canada
- ¹⁶ Personal communication, 3 Feb 10, with Dr. K. O'Hashi, General Manager, Nippon Steel Engineering Co.,Ltd., Energy Facilities, Civil Engineering & Marine Construction Division
- ¹⁷ http://www.ftloutreach.com/images/FTL_Final_Report-Feasibility_Study_4-30-07.doc
- ¹⁸ Personal communication, Eric Elrod, Koch Industries
- ¹⁹ IEEE Power & Energy Magazine, Vol 7, No 6, Nov-Dec 09
- ²⁰ Renewable Energy Focus, Nov-Dec 07, p. 34-37
- ²¹ Personal Communication 15 April 11 with Steve Catha, Smart Pipe Company, Inc., Houston <http://www.smart-pipe.com/>

²² George Parks, ConocoPhillips, presentation, 25 Sept 06, ASME International Pipeline Conference, Calgary, AB, Canada. Second panel forum, "Hydrogen Pipeline Transmission: Updates and Opportunities"

²³ Crotagino, F., Huebner, S. (2008) Energy storage in salt caverns: developments and concrete projects for adiabatic compressed air and for hydrogen storage, KBB Underground Technologies GMBh, Hannover, Germany. SMRI Spring Technical Meeting, Porto, Portugal, 28-29 Apr 08.

²⁴

<http://www.energy.iastate.edu/Renewable/ammonia/ammonia/ammoniaMtg09.htm>

²⁵ Schwatz, M., Elliott, D., Gower, G. (1993) Seasonal variability of wind electric potential in the United States. PNL, 01 Jul 93, OSTI 10178386, DE93018182, PNL-SA-22090.

²⁶ Technology Review, Vol 114 No 3, June 2011, p 28-29, MIT, 'Water Power'

²⁷ Turner, J. (2004) Sustainable Hydrogen Production. Science 13 August 2004: Vol. 305 no. 5686 pp. 972-974
<http://www.sciencemag.org/content/305/5686/972.full>

²⁸ Leighty W, Hirata M, O'Hashi K, Benoit J. International renewable hydrogen transmission demonstration facility (IRHTDF). Nineteenth World Energy Congress, Sydney, September 2004 (From: <http://www.leightyfoundation.org/files/WorldEnergyCongressSydney.pdf>).

²⁹ http://energy.gov/media/DOE_StrategicPlan.pdf

³⁰ Issues in Science and Technology, Spring 2011, p 61-70, "The Smart Grid: Separating Perception from Reality", L.J. Makovich, Global Power Group, HIS Cambridge Energy Research Associates
Larry.makovich@ihs.com

³¹ Wald, M. (2010) How to Build the Supergrid. Scientific American, November 2010, p 57-61,

³² ConocoPhillips ANS gasline at:
http://www.ansnaturalgaspipeline.com/pdf/proposal_summary.pdf

³³

<http://www.electricitystorage.org/ESA/technologies/>

³⁴

<http://www.electricitystorage.org/ESA/technologies/>